

Investigation on Water Wetting in Large Diameter Horizontal and Slightly Inclined Oil-Water Pipe Flows

Xuanping Tang, Francois Ayello, Chong Li, Jiyong Cai* and Srdjan Nesic

Institute for Corrosion and Multiphase Technology

Ohio University

342 W. State St., Athens, OH 45701

U.S.A

Fax: 1-740-593-9949

*E-mail: cai@bobcat.ent.ohio.edu

C. Ivan T. Cruz* and Jamal N. Al-Khamis*

Saudi Aramco Oil Company

Box 6891

Dhahran, 31311

Saudi Arabia

Fax: 966-3-8734262

*E-mail: czarivan.cruz@aramco.com; jamal.khamis@aramco.com

ABSTRACT

Internal corrosion in oil production and transportation pipelines is always associated with the presence of corrosive water, and the likelihood of corrosion generally increases with the volume fraction of water. When corrosive water wets the pipe internal wall, corrosion is possible. On the other hand, corrosion is free only when water entrainment occurs.

This paper outlines some results of phase wetting determination of model oil (LVT200) and extra light crude (AXL) oil testing series in large diameter horizontal and slightly inclined pipe flows. In this study, four main techniques (flow pattern visualization, wall conductance probes, corrosion monitoring and wall sampling) were used to determine the phase wetting on the internal wall of pipe at various superficial oil & water velocities and pipe inclinations.

Three types of phase wettings (stable water wetting, intermittent wetting and stable oil wetting) were observed. Based on the overlapping information from these techniques, comprehensive phase wetting maps for model oil and AXL crude oil tests were obtained at different pipe inclinations.

It was found that the oil type has a significant effect on the transition from stable oil wetting to intermittent wetting. Stable oil wetting occurs at much lower superficial oil

velocity for AXL oil than that for LVT200 oil. It is clear that pipe inclination also has a big effect on this transition line. In the upward inclined flow, increasing pipe inclination leads to an occurrence of stable oil wetting at lower superficial oil velocity. This trend is also true with decreasing the pipe inclination in the downward inclined flow.

Based on the results of corrosion monitoring, it was found that a complete absence of corrosion occurs only when oil wetting exists. Corrosion exists when stable water and intermittent wettings prevail.

Keywords: internal corrosion, oil-water two-phase flow, crude oil, phase wetting determination

1. INTRODUCTION

Crude oil and ground water with complex water chemistry are transported simultaneously in the oil pipelines. Different oil-water flow patterns, which lead to different distributions of oil and water phases on the cross-section of pipe, could exist. At low oil-water mixture velocity, water phase could flow as a water layer on the bottom of the pipe. However, at high oil velocity, water phase could be entrained by the flowing oil phase and flows as droplets in the continuum of the oil phase. Since some corrosive gases, such as CO_2 and H_2S , dissolve in the water phase and water is corrosive. In the fields, most of crude oil transport pipelines are made of carbon steel. Once corrosive water wets the pipe inner wall, corrosion could exist in these transportation lines. The likelihood of corrosion generally increases with the volume fraction of water. Of course, the wetting behavior of water phase and corrosion is affected by other factors: the water chemistry, type of oil, additives, flow regime, velocity and surface condition of pipe wall, etc.

Corrosion is absent only when crude oil wets the internal wall of pipeline. Typically, this occurs only when water entrainment (oil wetting) happens. With increasing water cut and decreasing the oil velocity, water droplets interaction each other and coalesce into bigger one. Gradually bigger droplets will 'breaks' out, and eventually forms a continuous water layer on the bottom of pipe at certain flowing conditions.

However, water wetting is one of the missing links in our current understanding of internal corrosion in oil and gas industry. In the past, the effect of these parameters has been considered only in a qualitative sense. No extensive experimental studies on this topic have been done. It is a great challenge for corrosion engineers to determine more precisely the flow conditions leading to corrosion and conversely the conditions leading to entrainment of the free water layer by the flowing oil phase.

During last three decades, little experimental and numerical modeling work has been

performed. The first simplified water wetting model, which was used to predict the critical oil velocity needed to sweep out the settled water in the pipe, was proposed by Wicks and Fraser¹ (1975). This model was only based on limited experimental results. It was suitable for predicting the critical velocity primarily for very low water cut situations. At high water cuts, the model significantly underestimated the critical velocity needed for entrainment. In 1987, L.M. Smith et al.² pointed out that the ability of oils to carry water is up to a 20% water cut, if flowing at velocities larger than 1 m/s. C. de Waard and Lotz³ (1993) argued that the presence of the hydrocarbon phase was accounted through a so-called water-wetting factor. Based on the original experiments of Wicks and Fraser¹ a binary prediction factor was extracted suggesting that oil-wetting will occur only for water cuts less than 30% and oil velocity larger than 1 m/s, when all water can be entrained in the oil phase. In another model published the same year (1993), Adams et al.⁴ pointed out that three types of phase wettings could occur and estimated that below 30% water cut the tubing will be oil-wet; from 30-50%, intermittent water wetting occurs, and over 50% the tubing is water wet. Obviously, these are very crude criteria that neglect or oversimplify the effects of varying properties of the oil and water phases, the flow regime and the flow geometry. Furthermore, field experience suggests that in some cases corrosion was obtained at water cuts as low as 2%, in others no corrosion was obtained for water cuts larger than 50%. Wu⁵ in 1995 modified the Wicks and Fraser¹ model; however no major advancement was achieved. C. de Waard et al.⁶ (2001 and 2003) updated their original empirical model³ and proposed a new empirical model using an analysis based on the emulsion breakpoint approach. A link between API gravity, emulsion stability and water wetting of steel by an oil-water mixture was considered by taking into account the changes of interfacial tensions in an oil-water-steel system. This was a major step forward from the original model. However, while agreeing reasonably well with the specific pool of field cases used for its calibration, this new model remains an empirical correlation built on limited field data with an uncertain potential for extrapolation. More importantly, this model does not consider the effect of pipe diameter, oil density, oil viscosity and system temperature on the critical velocity of the flowing oil phase required for entrainment.

As a part of Ohio University's newly released software package MULTICORP V3.0⁷, a mechanistic model (Cai et al.⁸⁻⁹) of water wetting prediction in oil/water and gas/oil/water systems is included. The effects of pipe diameter, pipe inclination, oil density, oil viscosity and system temperature on the critical velocity of the flowing oil phase required for entrainment are considered in that model⁸⁻⁹. It should be pointed out that the model has not been verified in the gas-oil-water three-phase flow and does not consider the effect of gas, steel surface state, chemical additives and type of crude oil on water wetting because of the lack of experimental and field data.

Since 2004, a series of comprehensive experimental studies on water wetting with model oil and different types of crude oils in large diameter horizontal and inclined oil-water pipe flows have been carried out in the Institute for Corrosion and

Multiphase Technology of Ohio University. Four very different techniques, wall conductance probes, wall sampling, flow pattern visualization and corrosion monitoring, have been used to determine the wetting behavior. In a recent paper published by Cai et al¹⁰, the authors pointed out that the model (Cai et al⁸⁻⁹, 2004) was in good agreement with experimental results obtained with the model oil. However, this model has not been verified by the results obtained under crude oil-water flow conditions.

In order to validate and improve the model (Cai et al⁸⁻⁹, 2004) with more experimental data obtained from large diameter pipelines, comprehensive experiments are carried out to determine the phase wetting in this study with four main techniques (wall conductance probes, corrosion monitoring, wall sampling and flow pattern visualization) at different superficial oil and water velocities in large diameter horizontal and slightly inclined model oil/crude oil-water pipe flows. Based on experimental results, comprehensive phase wetting maps for different oils at different pipe inclinations will be built. These phase wetting maps can be used as useful references and guidelines for corrosion engineers and pipeline operators to manipulate oil and gas systems under corrosion free conditions.

2. EXPERIMENTAL SETUP

The experiments have been conducted at the Institute for Corrosion and Multiphase Technology at Ohio University in a 200' long, 4" ID multiphase flow loop mounted on a fully inclinable rig, which is specially designed to investigate corrosion and multiphase flow under realistic flow conditions found in the field. FIGURE 1 shows the schematic of the fully inclinable multiphase flow rig. The same experimental setup was used for experiments described previously by Cai et al.¹⁰. A brief description for the experimental set-up is introduced in the following sections.

Oil is stored in a 1.2 m³ stainless steel storage tank. The tank is equipped with two 1 kW heaters and stainless steel cooling coils to maintain a constant temperature. Water with 1% wt. NaCl is stored in a 1.2 m³ stainless steel storage tank. Oil is pumped through the system using a Moyno pump equipped with a variable speed motor. The oil flow rate is precisely controlled within a range of 0.5 to 3 m/s with a combination of the variable motor speed and a bypass system. One of the two Moyno pumps (with small and high flow rate) are used to pump water through the system from the water storage tank.

Oil and water mix in the static T-mixer and then the oil-water mixture flows through a 3 m length flexible hose, which allows the inclination to be set at any angle for this fully inclinable rig, and then enters the 10 cm (4 inches) I.D., 14 m long stainless steel pipeline and then flows through a 2 m long upstream test section, where all measurements are carried out. Since the test section is set at 14 m downward from the

static T-mixer, the pipe has enough length for the development of flow structure and for the effects of pump and valves on flow structure to be eliminated. The test section is made of carbon steel. A 2 m long transparent pipe is connected to the carbon steel test section, which is used to visualize the flow pattern. After the oil-water mixture flows through a 180 degree bend, it enters into a 14 m long stainless steel pipe and another 2 m long transparent pipe is connected to the stainless steel pipe section and the 2 m long downstream test section, which is made of carbon steel. After the oil-water mixture leaves the downstream test section, it flows through a 20 m long 4 inch I.D PVC pipe and enters into the oil-water separator, where the separation process of oil and water takes place. After oil and water separate, water accumulates in the water boot and it flows through the valve at the bottom of water boot back to the water storage tank. Separated oil phase flows through the oil outlet pipe back to the oil storage tank for further circulation. It should be pointed out that all the components, except the test sections in this multiphase flow rig, are made of corrosion-free materials (either stainless steel or PVC).

Since corrosion measurement and monitoring is carried out in this study, in order to minimize the effect of oxygen on corrosion process, the whole flow system is de-oxygenated using pure carbon dioxide (CO₂) before water wetting experiments are started. The oxygen concentration in the system is always controlled below 25 ppb, which is allowable for corrosion measurements under this environment.

As abovementioned, two sections are used in current study. FIGURE 2 shows the schematic of the 2 m long carbon steel test section. During the experiments, the test section can be corroded which leads to an increase of Fe²⁺ ion concentration in the water phase. Five rows of wall conductance probes with staggered structure, one set of high frequency impedance probes, wall sampling port and ER probe holder are installed and located at the downstream portion of test section. The test section is connected with downstream and upstream pipe sections with two clamp flanges, which allow the test section being rotated in any angle.

Four main techniques (flow pattern visualization, wall conductance probes, corrosion monitoring and wall sampling) were used to determine phase wetting on the internal wall of pipe at different superficial oil and water velocities in large diameter oil-water horizontal & inclined flows.

All wall conductance probes are used to measure the water/oil content very close to the surface of the pipe internal wall. FIGURE 3(a) shows the wall conductance probes. The probes are epoxy-coated stainless steel pins with 0.45 mm O.D. threaded through a 0.5 mm I.D. hole in the pipe. In the downstream test section, five staggered rows of 18 probes (90 probes) are flush-mounted on the bottom half of the pipe wall circumference. However, 5 staggered rows of 32 probes (total 160 probes) are flush-mounted on the whole circumference of pipe inner wall in the upstream test section. FIGURE 3 (b) shows the staggered configuration of wall conductance probes.

This particular arrangement with a large number of spatially distributed probes is used to minimize the errors that plagued such similar effort in the past such as the effect of a water phase “snaking” around isolated probes. Also, this redundant configuration is very useful for characterizing the ‘gray zone’ (intermittent wetting) between stable oil wetting and stable water wetting and for eliminating outliers.

Visual recording were done at the transparent test section just downstream of the main carbon steel test section. Artificial coloring of the water was used to enhance the contrast between oil and water phases. The visual technique works very well with clear model oils and is not suitable for the tests with crude oils.

A wall sampling method, which is used to verify and check the results from the wall conductance probes, is used to measure the water/oil content very close to the surface of pipe inner wall by extracting the fluid from the bottom of pipe. A combination of a very precisely controlled needle valve and a solenoid valve used to extract the fluid very close the wall surface through the wall sampling port is shown in FIGURE 2. The instrumentation is carefully calibrated so the proper extraction time and suction is applied to minimize erroneous readings.

Since a CO₂ saturated water/oil mixture is circulated through the flow loop it is straightforward to conduct corrosion measurements on mild steel test section. The corrosion process enables an alternative way to determine water wetting. If water wetting occurs in a given test, corrosion happens as well. This will manifest itself as a rise in dissolved ferrous ion (Fe²⁺) concentration in the water phase, which can be easily detected by sampling the water and employing a standard colorimetric technique. An ER probe mounted in the test section can also used to monitor the corrosion rate and indirectly determine the water wetting.

It is anticipated that by using at 4 very different techniques for detection of water wetting as abovementioned, overlapping information will reinforce our confidence in the overall results and yield a stronger base for water wetting modeling.

3. RESULTS AND DISCUSSIONS

In this study, two main test series of experiments were conducted by using LVT200 model/AXL crude oil and 1 wt% NaCl brine saturated with CO₂. Different flow conditions were applied in horizontal & slightly inclined pipe flows. The most important parameters and test matrix are shown in TABLE 1 below. The properties of the oils of LVT200 and AXL at 25 °C are listed in TABLE 2. It is seen that the properties of AXL crude oil are close to those of LVT200 model oil.

TABLE 1 Main Test Parameters

Oil Phase	LVT200 oil and AXL crude oil
Water Phase	1% NaCl solution
Superficial Water Velocity, V_{sw}	0 ~ 0.22 m/s
Superficial Oil Velocity, V_{so}	0.5 ~ 2.5 m/s
Water Cut, ϵ	0 ~ 20%
Pipe Inclination	Horizontal (for LVT200 test series) Horizontal, $\pm 2^\circ$ and $\pm 5^\circ$ (for AXL test series)
Pipe Diameter	4"
System Temperature	25 °C
System Pressure	0.13 MPa

TABLE 2 Properties of Oils at 25 °C

Oil Types	LVT200 Oil	AXL Crude Oil
Density, (kg/m ³)	825	830.4
Viscosity, (cP)	2	4.7
Surface Tension, (dyne/cm)	29.96	28.14
Interfacial Tension, (dyne/cm)	38.44	26.22

3.1. Phase Wetting Maps

All the results obtained by the methods as abovementioned were cross validated. Based on these experimental data, phase wetting maps for LVT200 oil and AXL crude oil test series are generated at different pipe inclinations.

3.1.1 LVT200 Oil Test Series

FIGURE 4 shows the phase wetting map of mixture of LVT200 oil and 1% NaCl water in horizontal pipe flow. It is clear that three types of phase wettings (stable water, intermittent and stable oil wettings) exist. Intermittent wetting is dominant at oil-water mixture velocity ranged from 0.5 m/s and 1.5 m/s and water cut less than 10%. Water wetting occurs when water cut is higher than 10% at same oil-water mixture velocity range. However, water entrainment (oil wetting) occurs when oil-water mixture velocity is higher than 1.5 m/s and water cut lower than 10%. All water phase flows as water droplets in the oil phase. Oil and water form stable water-in-oil dispersed flow. At the oil-water mixture velocity lower than 1 m/s, increasing water cuts leads to a transition from intermittent wetting to stable water wetting since the coalescence of water droplets is getting stronger and leads

to the formation of bigger water droplets. On the other side, oil phase could not afford enough energy to break up these bigger droplets. More big water droplets drop out of oil phase and gradually form a stable water layer at the bottom of pipe. However, at the oil-water mixture velocity higher than 1.5 m/s, increasing water cut leads to a transition from stable oil wetting to intermittent wetting. Since the oil-water turbulence is very high and prevents the coalescence of small water droplets, it is very difficult to form a stable water wetting at this oil-water mixture velocity range since the oil-water turbulence is very high and prevents the coalescence of small water droplets.

3.1.2 AXL Crude Oil Test Series

FIGURE 5 shows the phase wetting maps for AXL oil tests in horizontal pipe flows. It is seen that three types of phase wetting (stable water, intermittent and stable oil wettings) are clearly observed. Water wetting prevails at oil-water mixture velocity lower than 1 m/s and water cut higher than 5%. It disappears when the oil-water mixture velocity is higher than 1 m/s. When the oil-water mixture velocity is higher than 1.0 m/s and water cut lower than 10%, oil wetting is dominant. However, oil wetting still occurs at oil-water mixture velocity 0.7 m/s with water cut around 3%. Within current test conditions, intermittent wetting only exists in a narrow area.

Increasing pipe inclination up to 2 degrees leads to an appearance of stable oil wetting occurring at much lower oil-water mixture velocity (FIGURE 6), compared to that for horizontal flow. It even occurs at oil-water mixture velocity of 0.6 m/s and water cut around 2%. It is clear that oil wetting prevails at oil-water mixture velocity higher than 1 m/s and water cut up to 15%. Stable water wetting disappears at water cut lower than 20% within current test oil-water mixture velocity. Intermittent wetting dominates at oil-water mixture velocity lower than 1 m/s. In 5° upward inclined flow (FIGURE 7), oil wetting dominates at water cut lower than 15% and oil-water mixture velocity of 1.5 m/s. Compared to the phase wetting map at pipe inclination of 2 degree, the stable oil wetting area at pipe inclination of 5 degree is much bigger. From the phase wetting maps at pipe inclinations of 2° and 5°, it is seen that stable water wetting could not survive in the upward inclined pipe flow. It can be argued that water layer could not form because of the effect of gravity force.

The phase wetting maps at pipe inclinations of -2° and -5° are shown in FIGURE 8 and FIGURE 9, respectively. At 2° downward inclined flow, stable water wetting occurs at oil-water mixture velocities ranged from 0.6 m/s to 0.8 m/s and water cut higher than 15%. Within this oil-water mixture velocity range, decreasing the pipe inclination to -5° leads to occurrence of stable water wetting at water cut higher than 20%. From both phase wetting maps, it is seen that stable water wetting disappears when the mixture velocity is higher than 0.8 m/s. On the

other side, it is obvious that oil wetting prevails at the mixture velocity higher than 1 m/s and water cut up to 20%. The area for intermittent wetting is much smaller than that for oil wetting.

3.2 Transition Line between Stable Oil Wetting and Intermittent Wetting

Based on the experimental results, it was found that corrosion is eliminated only when oil wetting occurs. From the corrosion point of view, it is very important for corrosion engineers to determine the flowing conditions, which lead to a transition from stable oil wetting to intermittent wetting. In order to clearly find out this transition, the phase wetting map as abovementioned are re-plotted (FIGURE 10 - FIGURE 12) with respect to the relationship between superficial oil velocity and superficial water velocity. The solid line in these plots presents the transition between stable oil wetting and intermittent wetting. The effects of oil type and pipe inclination on this transition line are discussed in the following sections.

3.2.1 Effect of Oil Type

FIGURE 15 shows the effect of oil types on the transition line from stable oil wetting to intermittent one. It is clear that the oil type has a significant effect on this transition line. Within current test conditions, it is seen that stable oil wetting only occurs at oil-water mixture velocity higher than 1.5 m/s in LVT200 oil-water horizontal flow. However, stable oil wetting exists at oil-water mixture velocity lower than 1 m/s for AXL crude oil tests. The stable oil wetting area for AXL oil is much bigger than that for LVT200 oil test. Although most of the physical properties of AXL oil are very close to those of LVT200 oil, the AXL oil-water interfacial tension is much lower than that of LVT oil and the chemical properties of AXL oil are much complex than those of model oil, which lead to a big difference on phase wetting behavior. More experimental work is needed to investigate the effects of chemical properties of crude oil and oil-water interfacial tension on wetting behavior.

3.2.2 Effect of Pipe Inclination

The phase wetting maps at pipe inclinations of 0° , $+2^\circ$ and $+5^\circ$ are shown in FIGURE 10 ~ 12. It is seen that the solid line (transition from stable oil wetting to intermittent wetting) shifts lower superficial oil velocity with increasing the pipe inclination. At the same superficial water velocity, oil wetting occurs at lower superficial oil velocity with increasing the inclination. In the upward inclined flow, water phase has the trend to flow back and accumulate because of the effect of gravity force. The component of the gravity force of the oil-water mixture opposite to the flow direction increases with the increasing of the inclination, which will be beneficial to the back mixing of the water and oil and consequently helps to form oil wetting.

The phase wetting maps at pipe inclinations of -2° and -5° are shown in FIGURE 13 and FIGURE 14. Compared to the phase wetting map at pipe inclination of 0° , it is clear that the transition line moves to the lower superficial oil velocity with decreasing of the inclination. It is easier to form oil wetting at inclined pipe flows. In the downward inclined flow, water phase moves faster than in the horizontal flow at same flowing conditions. The oil-water mixing on the oil-water interface in the downward inclined direction is stronger than that in the horizontal orientation. More water is entrained into oil phase, which leads to oil wetting occurring at lower superficial oil velocity.

The effect of pipe inclination on the transition line for the pipe inclinations as abovementioned is shown in FIGURE 16. It is seen that pipe inclination has a big effect on the transition line between oil and intermittent wettings. Also, it can be found that this effect is stronger in upward inclined flow than that in the downward inclined flow.

4. CONCLUSIONS

Four main techniques (flow pattern visualization, wall conductance probes, wall sampling and Fe^{2+} concentration monitoring) are used to detect phase wetting at different superficial oil and water velocities in large diameter horizontal LVT200 oil-water pipe flows and AXL oil-water pipe flows at different inclinations. According to experimental results, the following main points can be concluded:

- Extensive phase wetting maps for a model oil and AXL crude oil were built based on the overlapping information obtained from these techniques.
- Three types of phase wettings (stable water wetting, intermittent wetting and stable oil wetting) were determined.
- The oil wetting area on the AXL crude oil's phase map is much wider than that on the model oil. The oil type has a significant effect on the wetting behavior.
- Increasing the pipe inclination leads to a lower superficial oil velocity that leads to oil wetting.

ACKNOWLEDGEMENT

Financial support from Saudi Aramco Co. for Institute for Corrosion and Multiphase Technology of Ohio University is gratefully acknowledged.

REFERENCES

- 1 Wicks, M., and Fraser, J.P., "Entrainment of Water by Flowing Oil", *Materials Performance*, May 1975, pp. 9~12.
- 2 L.M.Smith, M.J.J. Simon Thomas and C. de Waard, "Controlling Factors in the Rate of CO₂ Corrosion", UK. *Corr.'87 Brighton*, 26-28 Oct., 1987.
- 3 C. de Waard and U. Lotz, "Prediction of CO₂ Corrosion of Carbon Steel", *Corrosion/93*, paper no. 69, (Houston, TX: NACE International, 1993).
- 4 C. D. Adams, J. D. Garber, F. H. Walters, C. Singh, "Verification of Computer Modeled Tubing Life Predictions by Field Data", *Corrosion/93*, paper no. 82, (Houston, TX: NACE International, 1993).
- 5 Wu, Y., "Entrainment Method Enhanced to Account fro Oil's Water Content", *Oil & Gas Technology*, Aug. 28, 1995, pp. 83~86.
- 6 C.de Waard, L.Smith and B.D. Craig, "The Influent of Crude Oil on Well Tubing Corrosion Rates", *EUROCORR* 2001.
- 7 S. Nesic, Jiyong Cai, Shihuai Wang, Ying Xiao and Dong Liu, *Ohio University Multiphase Flow and Corrosion Prediction Software Package MULTICORP V3.0*, Ohio University(2004).
- 8 Jiyong Cai, Srdjan Nesic and Cornelis de Waard, "Modeling of Water Wetting in Oil-Water Pipe Flow", *NACE 2004*, Paper No.04663, pp. 1-19, 2004.
- 9 Srdjan Nesic, Jiyong Cai and Kun-Lin John Lee, "A Multiphase Flow and Internal Corrosion Prediction Model for Mild Steel Pipelines", *NACE 2005*, Paper No.05556.
- 10 Jiyong Cai, Srdjan Nesic, Chong Li, Xuanping Tang, Francois Ayello, C. Ivan T. Cruz and Jamal N. Khamis, "Experimental Studies of Water Wetting in Large Diameter Horizontal Oil-Water Pipe Flows", *SPE 2005*, Paper No. 95512-PP.

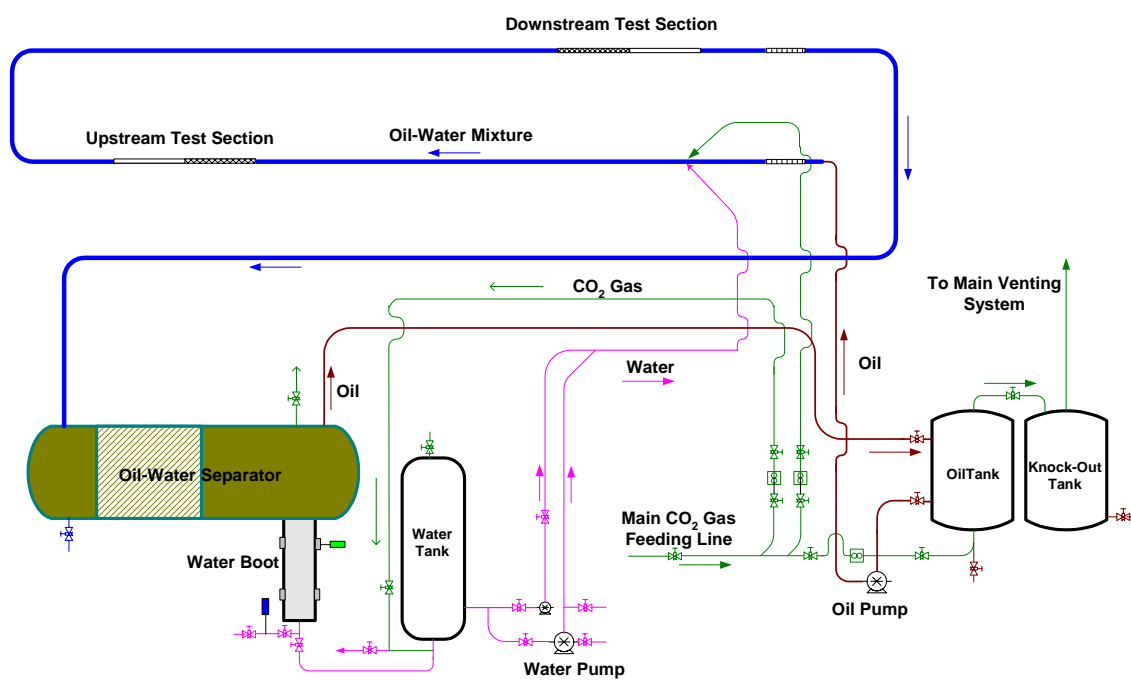

FIGURE 1 - Schematic of 4-inch I.D. fully inclinable multiphase flow loop

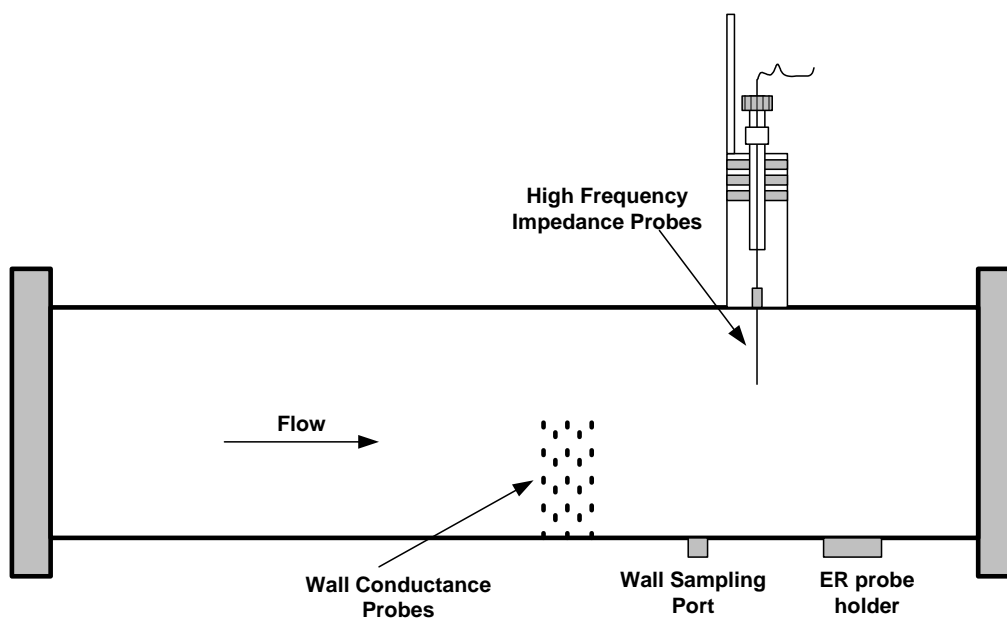

FIGURE 2 - Schematic of test section

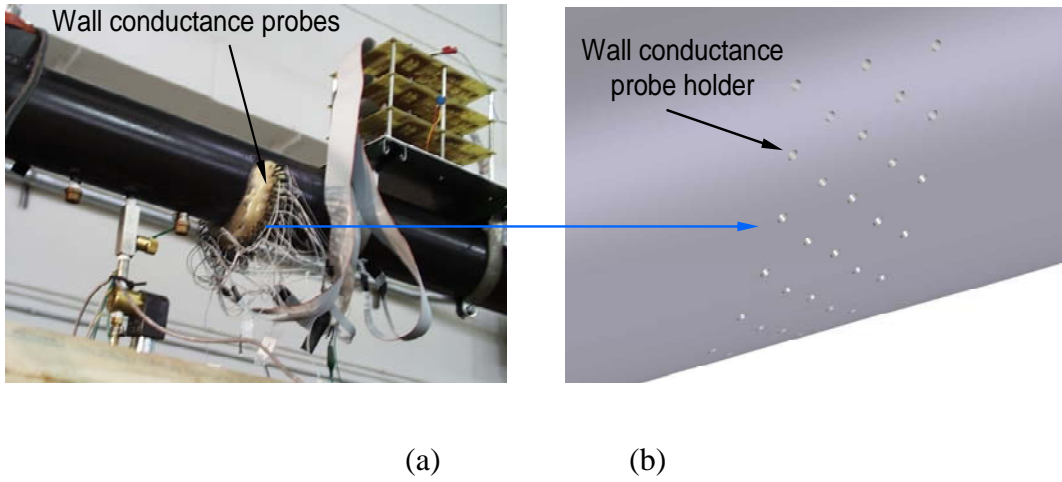

FIGURE 3 - Wall conductance probes
 (a): wall conductance probes on the test section
 (b): 5 rows of staggered configuration of probe holders

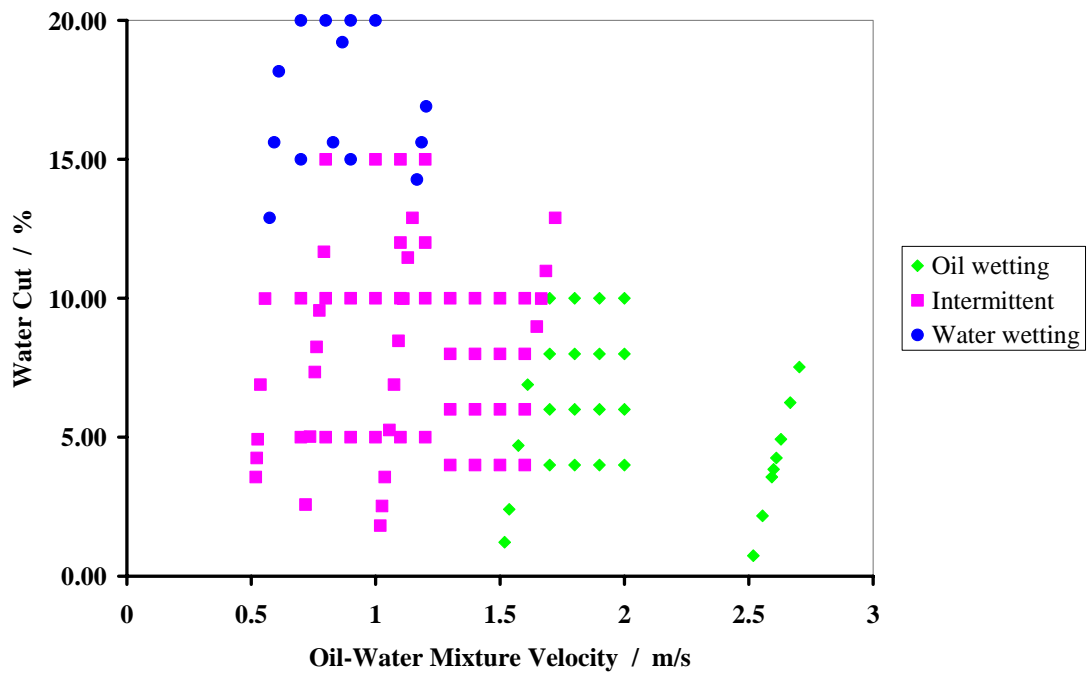

FIGURE 4 - Phase wetting map for LVT200 at different oil-water mixture velocities and water cuts in the horizontal oil-water two-phase flow

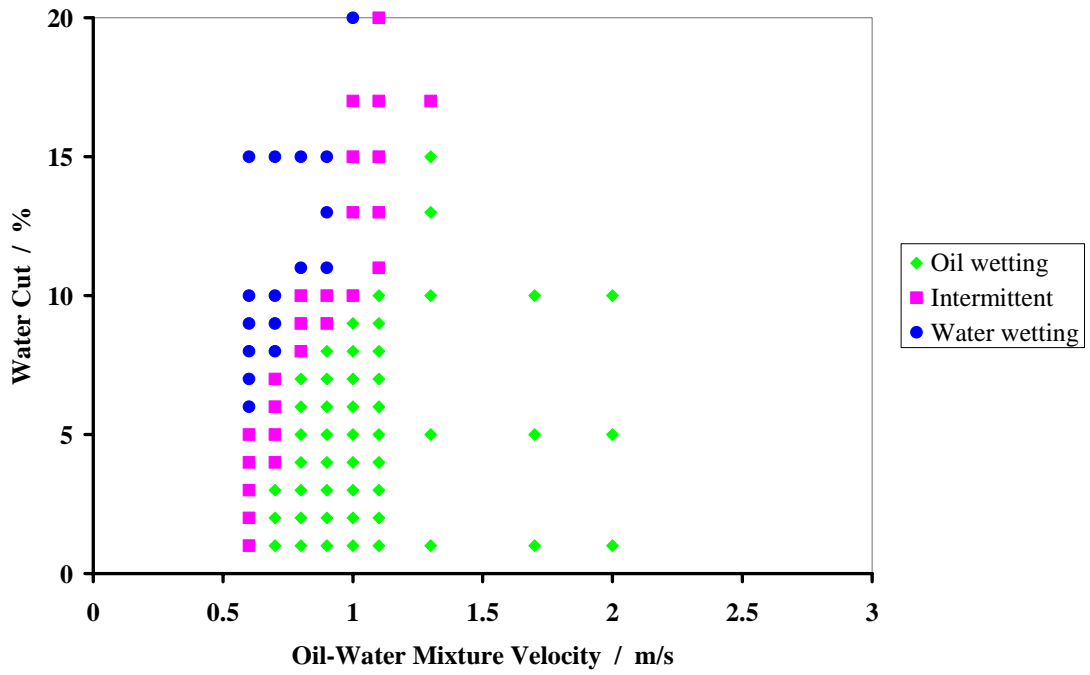

FIGURE 5 - Phase wetting map for AXL at different oil-water mixture velocities and water cuts in the horizontal oil-water two-phase flow

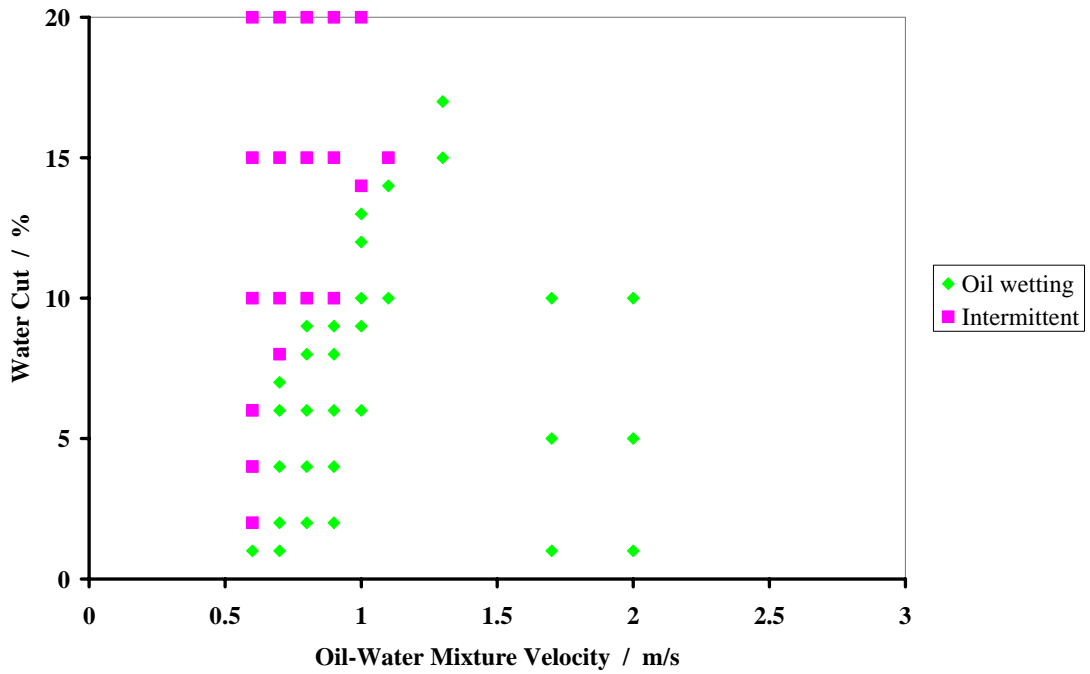

FIGURE 6 - Phase wetting map for AXL at different oil-water mixture velocities and water cuts in the 2 degree upward inclined oil-water two-phase flow

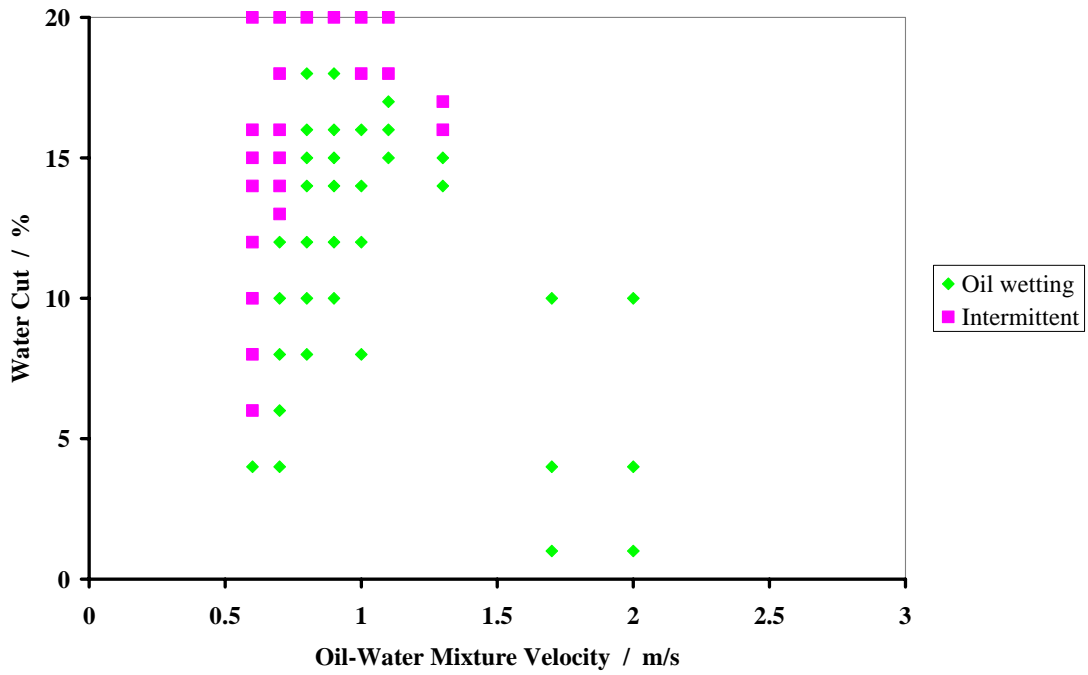

FIGURE 7 - Phase wetting map for AXL at different oil-water mixture velocities and water cuts in the 5 degree upward inclined oil-water two-phase flow

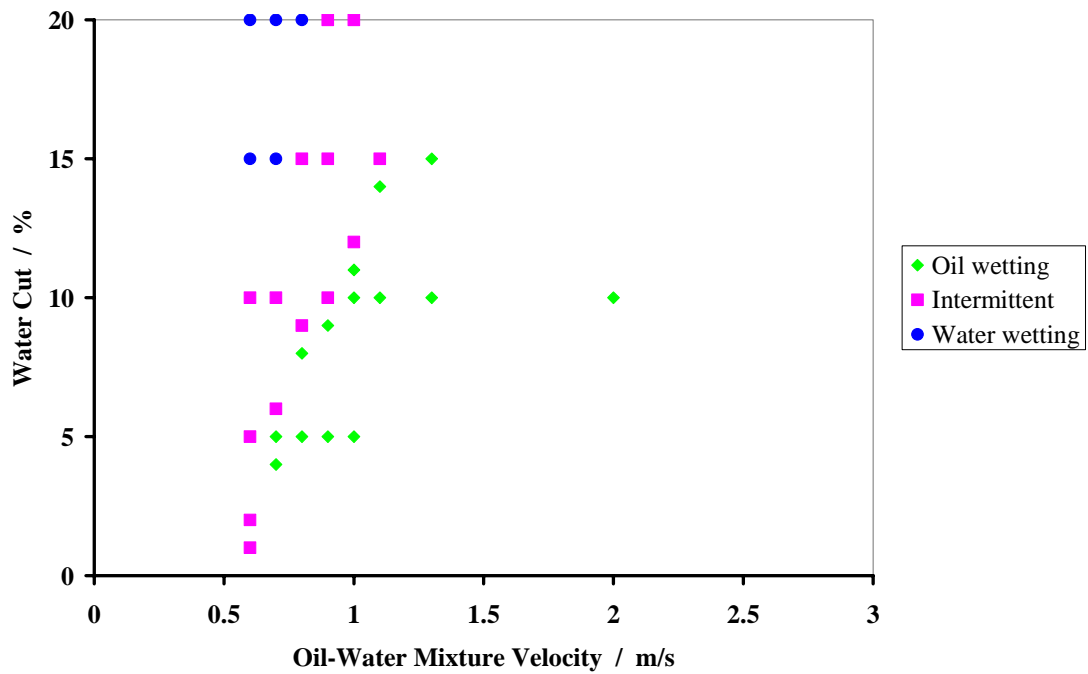

FIGURE 8 - Phase wetting map for AXL at different oil-water mixture velocities and water cuts in the 2 degree downward inclined oil-water two-phase flow

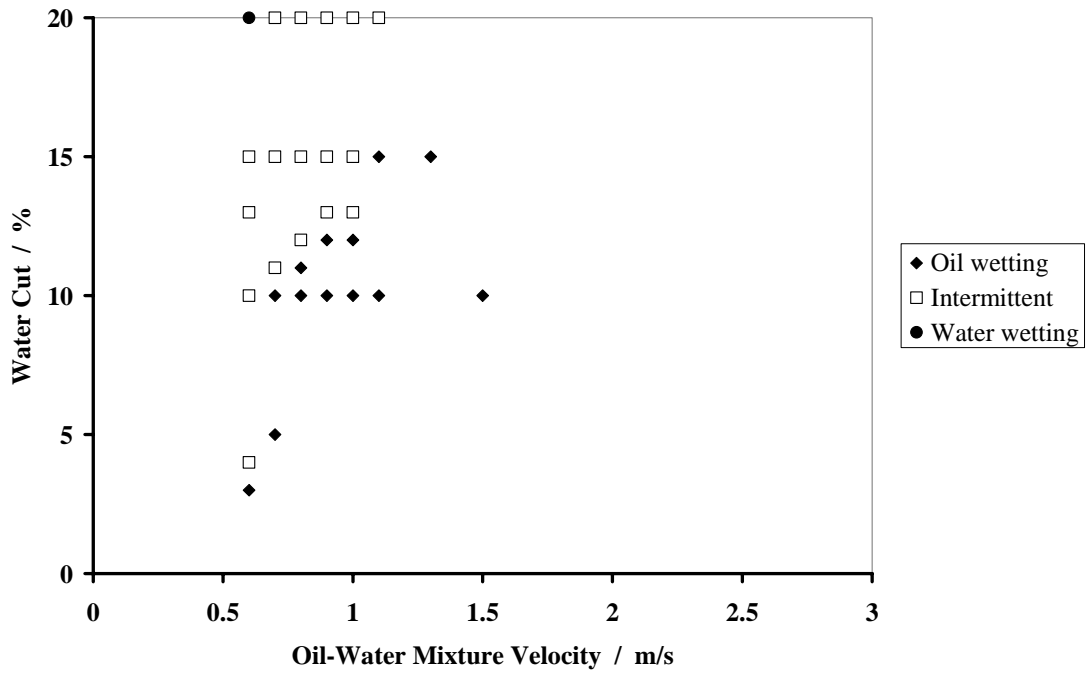

FIGURE 9 - Phase wetting map for AXL at different oil-water mixture velocities and water cuts in the 5 degree downward inclined oil-water two-phase flow

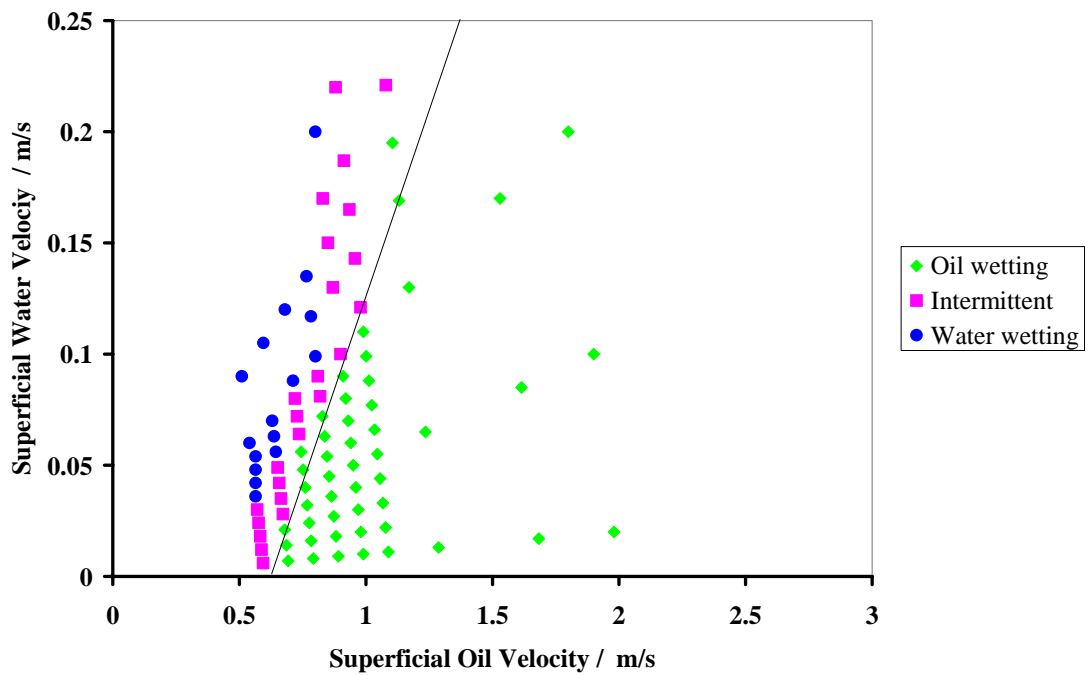

FIGURE 10 - Phase wetting map for AXL at different superficial oil and water velocities in the horizontal oil-water two-phase flow

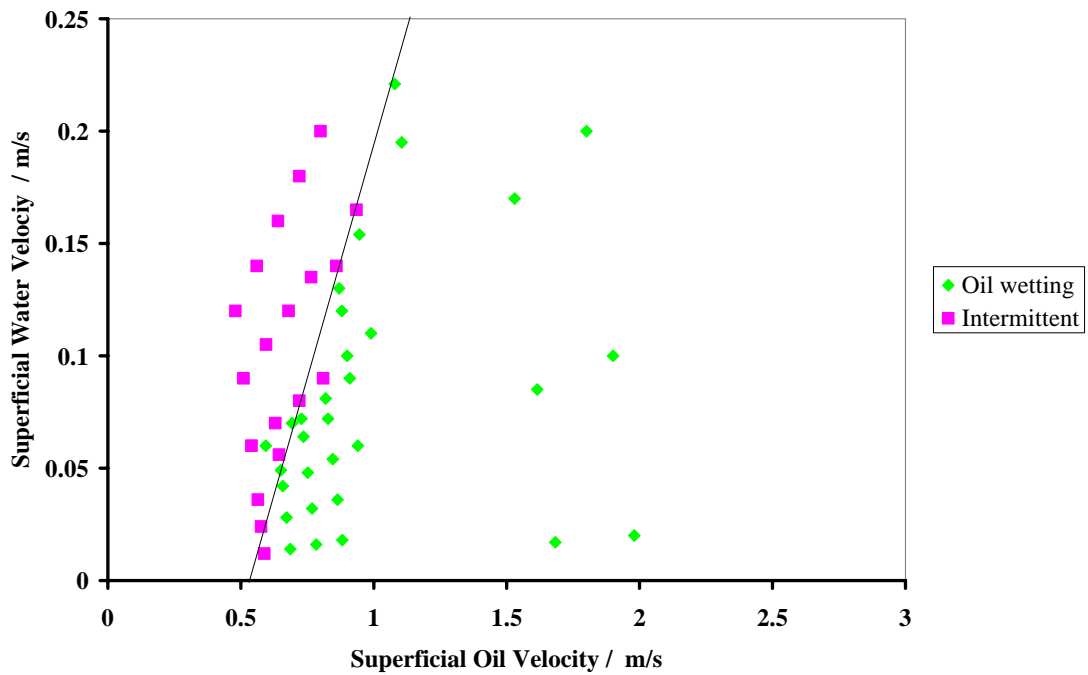

FIGURE 11 - Phase wetting map for AXL at different superficial oil and water velocities in the 2 degree upward inclined oil-water two-phase flow

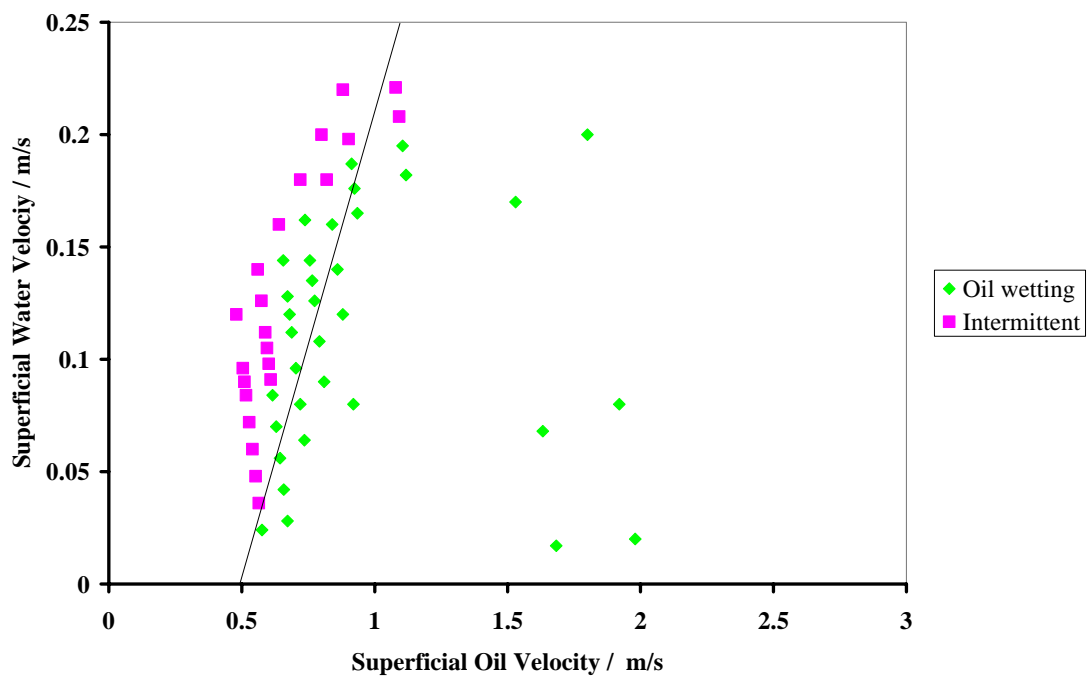

FIGURE 12 - Phase wetting map for AXL at different superficial oil and water velocities in the 5 degree upward inclined oil-water two-phase flow

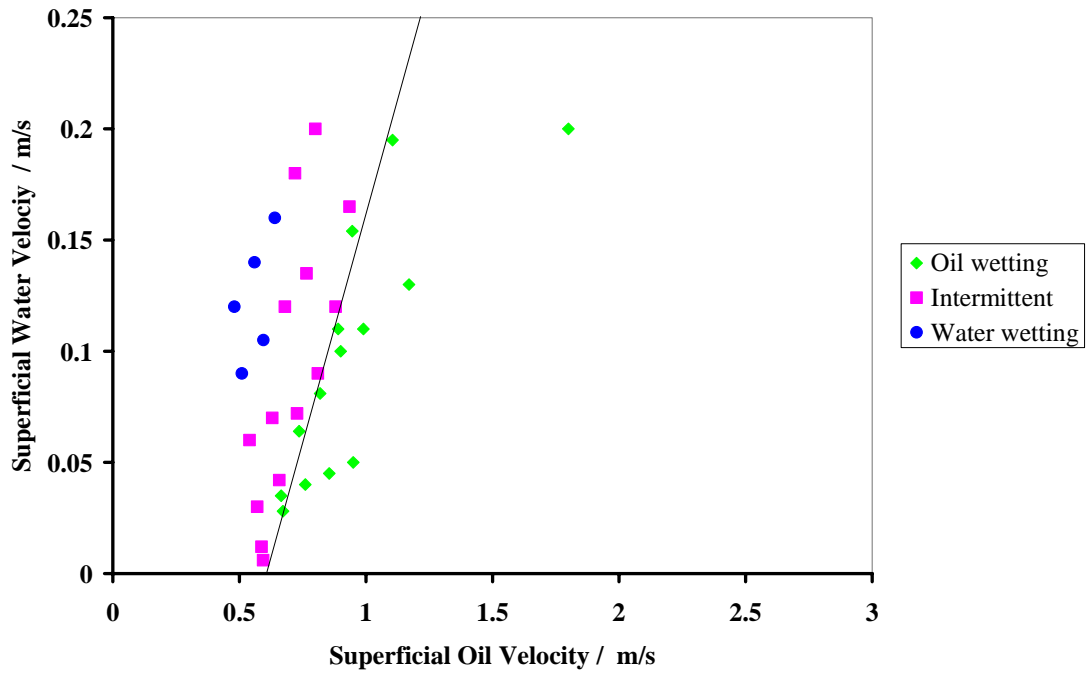

FIGURE 13 - Phase wetting map for AXL at different superficial oil and water velocities in the 2 degree downward inclined oil-water two-phase flow

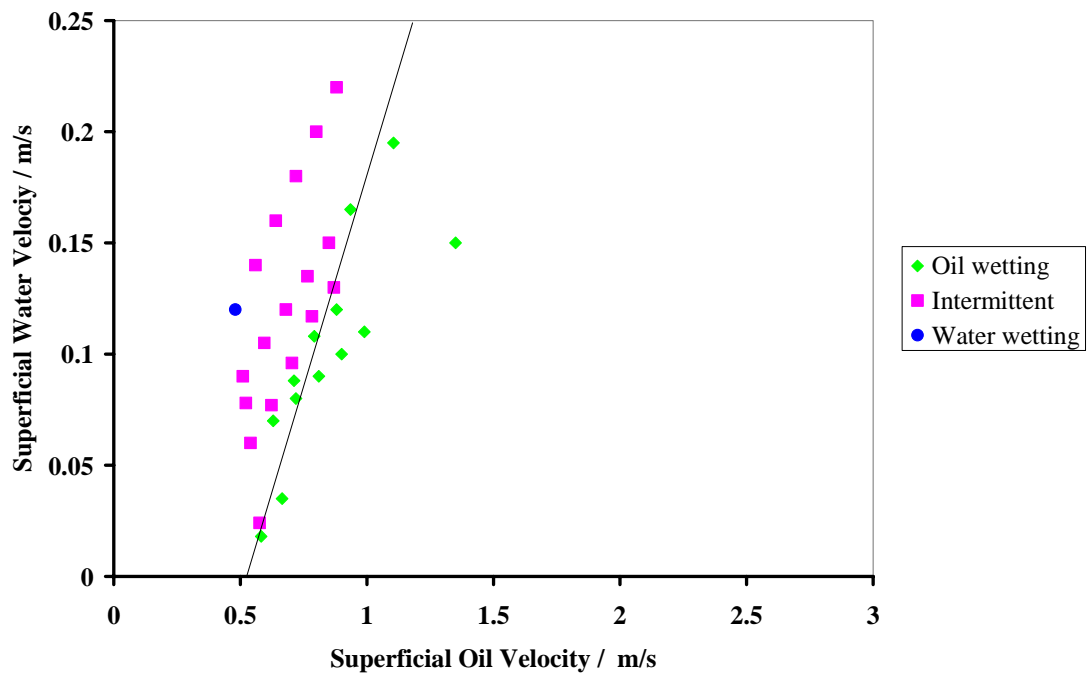

FIGURE 14 - Phase wetting map for AXL at different superficial oil and water velocities in the 5 degree downward inclined oil-water two-phase flow

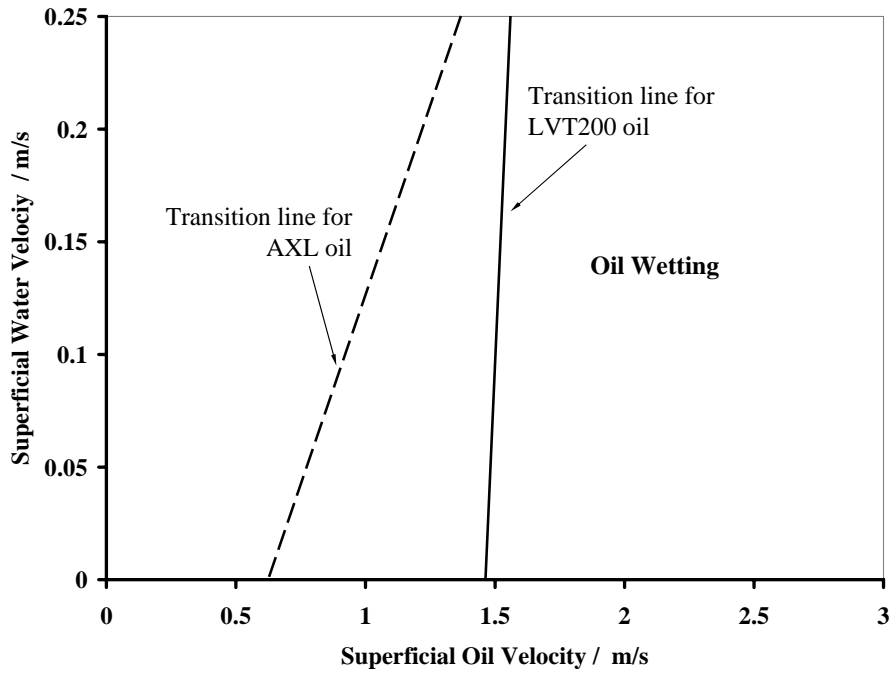

FIGURE 15 - Effect of oil type on the transition line from oil wetting to intermittent wetting in the horizontal pipe flow

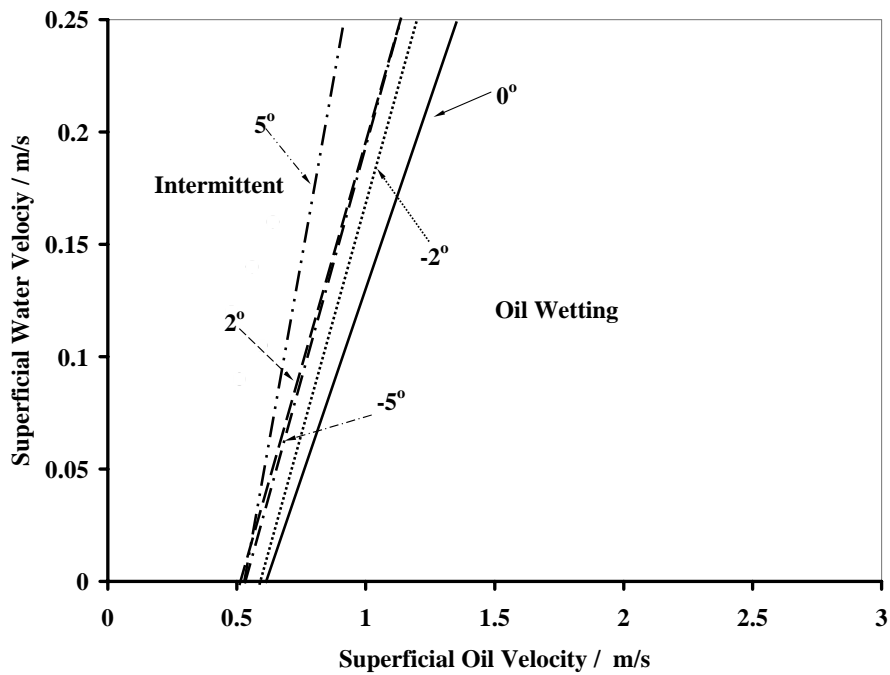

FIGURE 16 - Effect of pipe inclination on the transition from oil wetting to intermittent wetting for AXL crude oil tests